



REALTEK

NOT FOR PUBLIC RELEASE

RTL8201F-VB
RTL8201FL-VB
RTL8201FN-VB
RTL8201FR-VB

SINGLE-CHIP/PORT 10/100M ETHERNET PHYCEIVER WITH AUTO MDIX

WAKE-ON-LAN (WOL) APPLICATION NOTE (CONFIDENTIAL: Development Partners Only)

Rev. 1.3
24 July 2012
Track ID: JATR-3375-16



Realtek Semiconductor Corp.
No. 2, Innovation Road II, Hsinchu Science Park, Hsinchu 300, Taiwan
Tel.: +886-3-578-0211. Fax: +886-3-577-6047
www.realtek.com

COPYRIGHT

©2012 Realtek Semiconductor Corp. All rights reserved. No part of this document may be reproduced, transmitted, transcribed, stored in a retrieval system, or translated into any language in any form or by any means without the written permission of Realtek Semiconductor Corp.

DISCLAIMER

Realtek provides this document ‘as is’, without warranty of any kind. Realtek may make improvements and/or changes in this document or in the product described in this document at any time. This document could include technical inaccuracies or typographical errors.

TRADEMARKS

Realtek is a trademark of Realtek Semiconductor Corporation. Other names mentioned in this document are trademarks/registered trademarks of their respective owners.

LICENSE

This product is covered by one or more of the following patents: US5,307,459, US5,434,872, US5,732,094, US6,570,884, US6,115,776, and US6,327,625.

USING THIS DOCUMENT

This document is intended for the software engineer’s reference and provides detailed programming information.

Though every effort has been made to ensure that this document is current and accurate, more information may have become available subsequent to the production of this guide.

REVISION HISTORY

Revision	Release Date	Summary
1.0	2011/06/23	First release.
1.1	2011/07/27	Corrected minor typing errors.
1.2	2012/06/13	Corrected Table 22 Page 17, Reg19, Bit [2:0] (PMEB Pulse Width & Active Low/Pulse Low Settings), page 33.
1.3	2012/07/24	Revised section 6.2 Set Wake-Up Frame CRC, page 20.

Table of Contents

1. INTRODUCTION	1
2. PIN ASSIGNMENTS.....	2
2.1. RTL8201F (32-PIN).....	2
2.2. RTL8201FL (48-PIN).....	3
2.3. RTL8201FN (48-PIN).....	4
2.4. RTL8201FR (24-PIN).....	5
3. WAKE-ON-LAN (WOL) FLOW CHART	6
4. WAKE-ON-LAN (WOL) REGISTER SETTINGS (PAGE 17).....	7
5. UNIQUE PHYSICAL ADDRESS & MULTICAST REGISTER (REGISTERS 16~22).....	10
6. WAKE-UP FRAME MASK & CRC SETTING (PAGE 8~16, REGISTER 16~23).....	15
6.1. SET WAKE-UP FRAME MASK	15
6.2. SET WAKE-UP FRAME CRC	20
7. WAKE-ON-LAN (WOL) PIN TYPES	22
7.1. MII INTERFACE	22
7.2. RMII INTERFACE	23
8. MAGIC PACKET/WAKE-UP FRAME WAKEUP	24
8.1. WAKE-ON-LAN (WOL) CIRCUIT	25
8.1.1. RTL8201F PMEB Pin Function Selection.....	25
8.1.2. RTL8201FR PMEB Pin Function Selection	26
8.2. ACTIVE LOW WAKEUP	27
8.2.1. RX Isolate=1 (TX may or may not be set to isolated).....	29
8.2.2. RX Isolate=0 (TX Isolate=0).....	31
8.3. PULSE LOW WAKEUP	33
8.3.1. RX Isolate=1 (TX may or may not be set to isolated).....	34
8.3.2. RX Isolate=0 (TX Isolate=0).....	36

List of Tables

TABLE 1.	PAGE 17, REGISTER 16	9
TABLE 2.	PAGE 17, REGISTER 17	9
TABLE 3.	MULTICAST PATTERN AND REGISTER	12
TABLE 4.	PAGE 18.....	14
TABLE 5.	PAGE 8 (WAKE-UP FRAME 0)	16
TABLE 6.	PAGE 9 (WAKE-UP FRAME 1)	17
TABLE 7.	PAGE 10 (WAKE-UP FRAME 2).....	17
TABLE 8.	PAGE 11 (WAKE-UP FRAME 3).....	17
TABLE 9.	PAGE 12 (WAKE-UP FRAME 4).....	18
TABLE 10.	PAGE 13 (WAKE-UP FRAME 5).....	18
TABLE 11.	PAGE 14 (WAKE-UP FRAME 6)	19
TABLE 12.	PAGE 15 (WAKE-UP FRAME 7)	19
TABLE 13.	PAGE 16 (WOL_WAKE_CRC).....	20
TABLE 14.	MII INTERFACE.....	22
TABLE 15.	RMII INTERFACE	23
TABLE 16.	PAGE 17, REG19, BIT15 (RX ISOLATE ENABLE) (ACTIVE LOW)	27
TABLE 17.	PAGE 17, REG19, BIT14 (RXC HALT/TOGGLE SELECTION) (ACTIVE LOW)	28
TABLE 18.	PAGE 7, REG20, BIT15 (TX ISOLATE ENABLE) (ACTIVE LOW).....	28
TABLE 19.	PAGE 17, REG19, BIT15 (RX ISOLATE ENABLE) (PULSE LOW)	33
TABLE 20.	PAGE 17, REG19, BIT14 (RXC HALT/TOGGLE SELECTION) (PULSE LOW)	33
TABLE 21.	PAGE 7, REG20, BIT15 (TX ISOLATE ENABLE) (PULSE LOW).....	33
TABLE 22.	PAGE 17, REG19, BIT [2:0] (PMEB PULSE WIDTH & ACTIVE LOW/PULSE LOW SETTINGS)	33

List of Figures

FIGURE 1.	RTL8201F QFN-32 PIN ASSIGNMENTS	2
FIGURE 2.	RTL8201FL LQFP-48 PIN ASSIGNMENTS	3
FIGURE 3.	RTL8201FN QFN-48 PIN ASSIGNMENTS	4
FIGURE 4.	RTL8201FR QFN-24 PIN ASSIGNMENTS	5
FIGURE 5.	WAKE-ON-LAN (WOL) FLOW CHART	6
FIGURE 6.	UNICAST APPLICATION	10
FIGURE 7.	MULTICAST APPLICATION	11
FIGURE 8.	SET WAKE-UP FRAME MASK.....	15
FIGURE 9.	RTL8201F WAKE-ON-LAN (WOL) CIRCUIT.....	25
FIGURE 10.	RTL8201FR WAKE-ON-LAN (WOL) CIRCUIT.....	26
FIGURE 11.	MII RX ISOLATION TIMING	27
FIGURE 12.	RMII RX ISOLATION TIMING	27
FIGURE 13.	WOL WAVEFORM WITH RX ISOLATE=1 IN MII MODE (ACTIVE LOW)	29
FIGURE 14.	WOL WAVEFORM WITH RX ISOLATE=1 IN RMII MODE (ACTIVE LOW).....	30
FIGURE 15.	WOL WAVEFORM WITH RX ISOLATE=0 AND TX ISOLATE=0 IN MII MODE (ACTIVE LOW)	31
FIGURE 16.	WOL WAVEFORM WITH RX ISOLATE=0 AND TX ISOLATE=0 IN MII MODE (ACTIVE LOW)	32
FIGURE 17.	WOL WAVEFORM WITH RX ISOLATE=1 IN MII MODE (PULSE LOW)	34
FIGURE 18.	WOL WAVEFORM WITH RX ISOLATE=1 IN RMII MODE (PULSE LOW).....	35
FIGURE 19.	WOL WAVEFORM WITH RX ISOLATE=0 AND TX ISOLATE=0 IN MII MODE (PULSE LOW).....	36
FIGURE 20.	WOL WAVEFORM WITH RX ISOLATE=0 AND TX ISOLATE=0 IN RMII MODE (PULSE LOW)	37

1. Introduction

The RTL8201F/FL/FN/FR-VB can monitor the network for a Wake-Up Frame or a Magic Packet, and notify the system via the PMEB (Power Management Event; 'B' means low active) pin when such a packet or event occurs. The system can then be restored to a normal state to process incoming jobs.

The PME pin needs to be connected with a 4.7k ohm resistor and pulled up to 3.3V or 5V. When the Wake-Up Frame or Magic Packet is sent to the PHY, the PME pin will be set low to notify the system to Wake-Up. The PME pin can accept two waveform formats:

- Active Low Wake-Up (details in section 8.2, page 27)
- Pulse Low Wake-Up (details in section 8.3, page 33)

A Magic Packet Wake-Up occurs only when the following conditions are met:

- The destination address of the received Magic Packet is acceptable to the RTL8201F/FL/FN/FR-VB, e.g., a broadcast, multicast, or unicast packet addressed to the RTL8201F/FL/FN/FR-VB.
- The received Magic Packet does not contain a CRC error.
- The Magic Packet pattern matches, i.e., 6 * FFh + MISC (can be none) + 16 * DID (Destination ID) in any part of a valid Ethernet packet.

A Wake-Up Frame event occurs only when the following conditions are met:

- The destination address of the received Wake-Up Frame is acceptable to the RTL8201F/FL/FN/FR-VB, e.g., a broadcast, multicast, or unicast address to the current RTL8201F/FL/FN/FR-VB.
- The received Wake-Up Frame does not contain a CRC error.
- The 16-bit CRC of the received Wake-Up Frame matches the 16-bit CRC of the sample Wake-Up Frame pattern given by the local machine's OS. Or, the RTL8201F/FL/FN/FR-VB is configured to allow direct packet wake-up, e.g., a broadcast, multicast, or unicast network packet.

Note 1: 16-bit CRC: The RTL8201F/FL/FN/FR-VB supports eight long wake-up frames (covering 128 mask bytes from offset 0 to 127 of any incoming network packet). CRC16 polynomial= $x^{16}+x^{12}+x^5+1$.

Note 2: The RTL8201F/FL/FN/FR-VB provides a 296-bit eFUSE space for MAC programming.

2. Pin Assignments

2.1. RTL8201F (32-Pin)

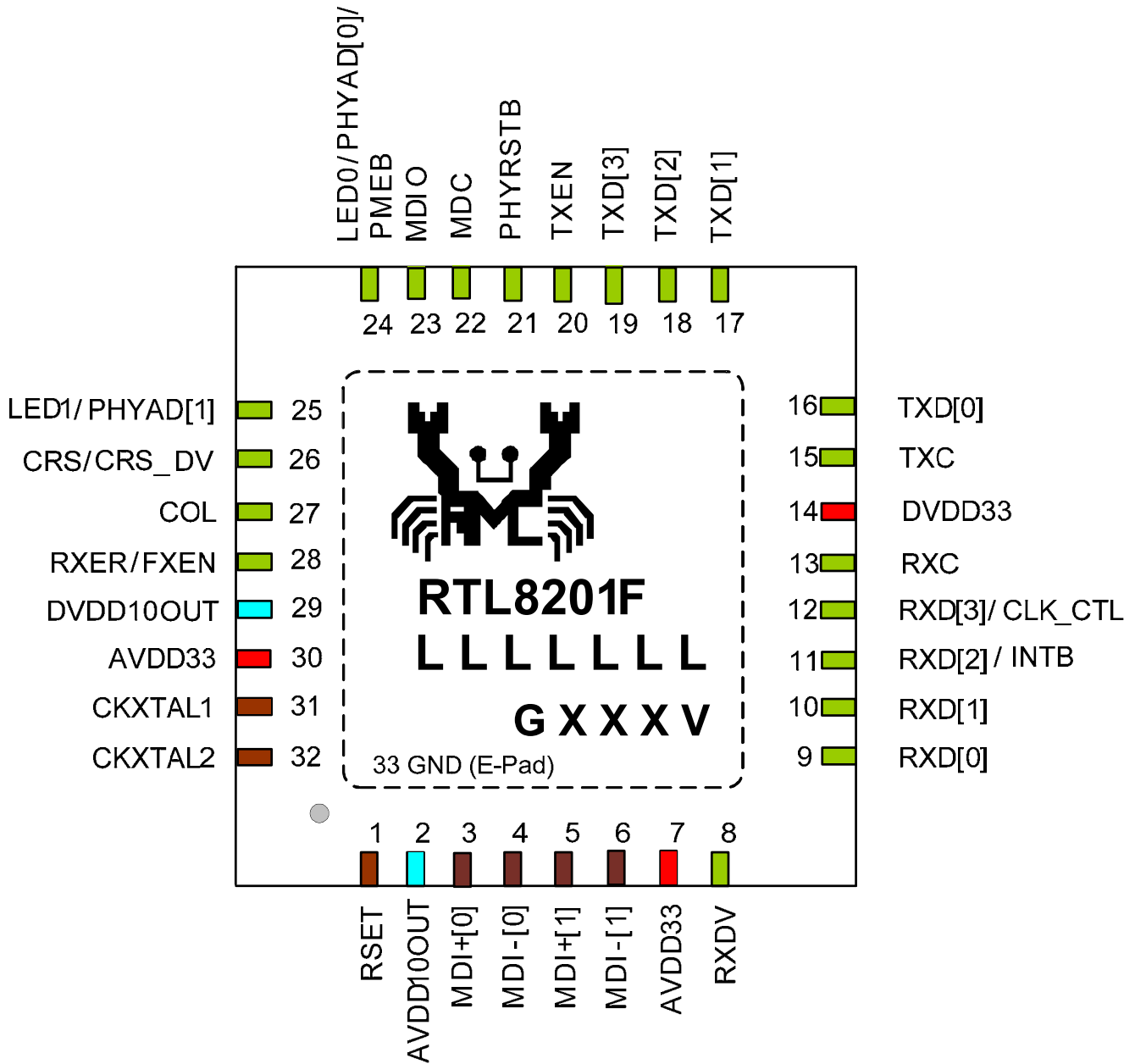

Figure 1. RTL8201F QFN-32 Pin Assignments

2.2. RTL8201FL (48-Pin)

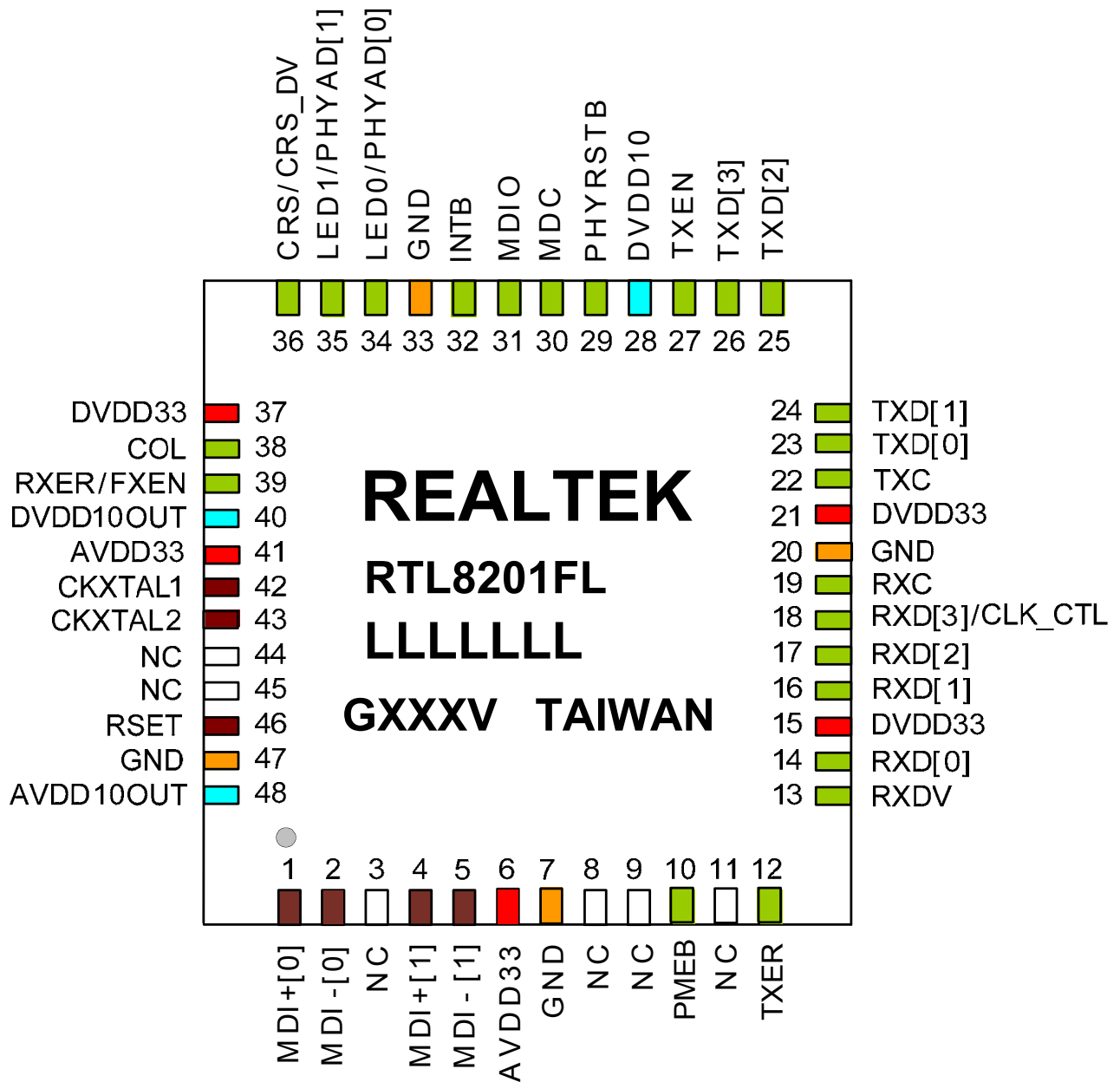

Figure 2. RTL8201FL LQFP-48 Pin Assignments

2.3. RTL8201FN (48-Pin)

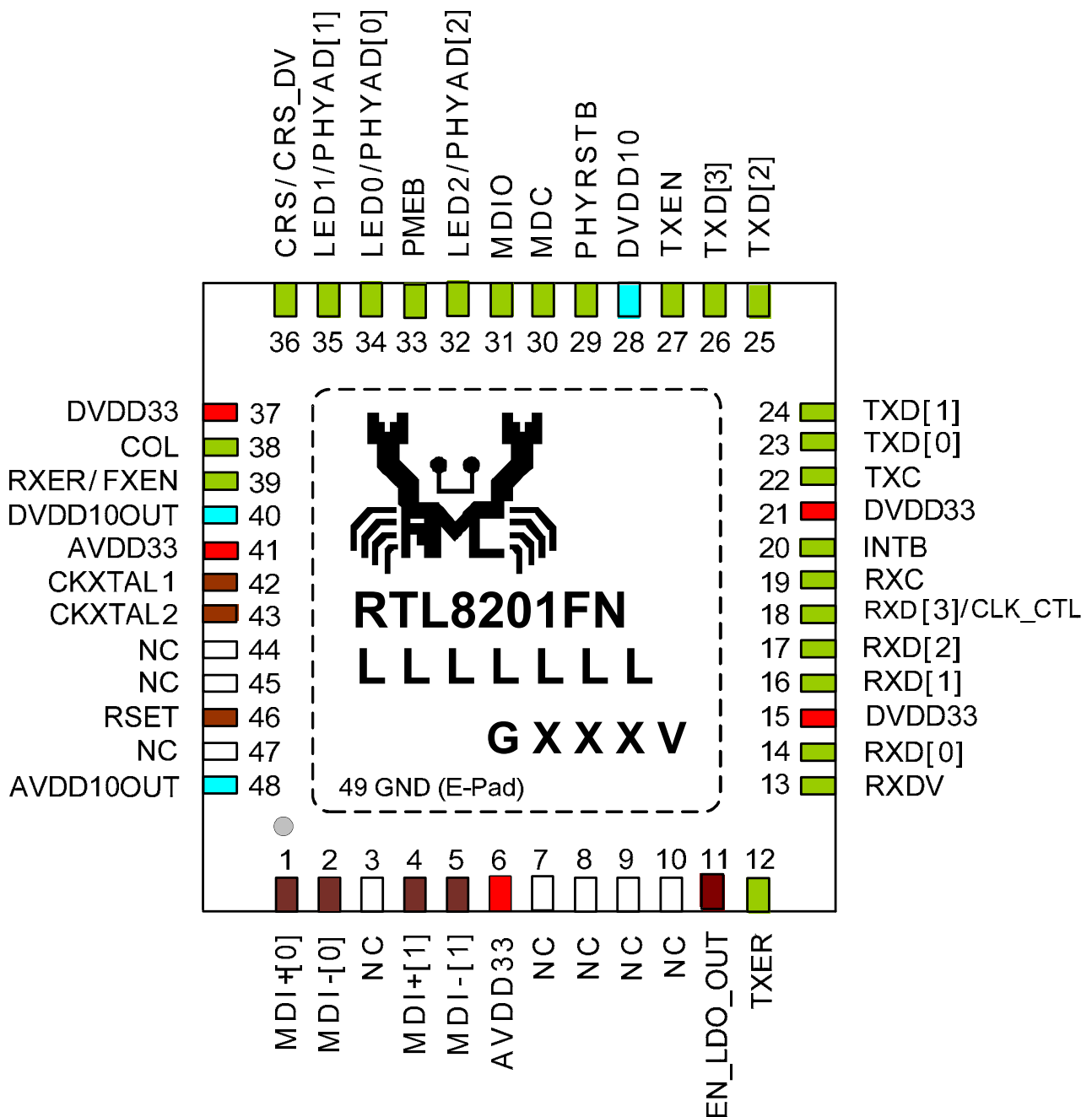

Figure 3. RTL8201FN QFN-48 Pin Assignments

2.4. RTL8201FR (24-Pin)

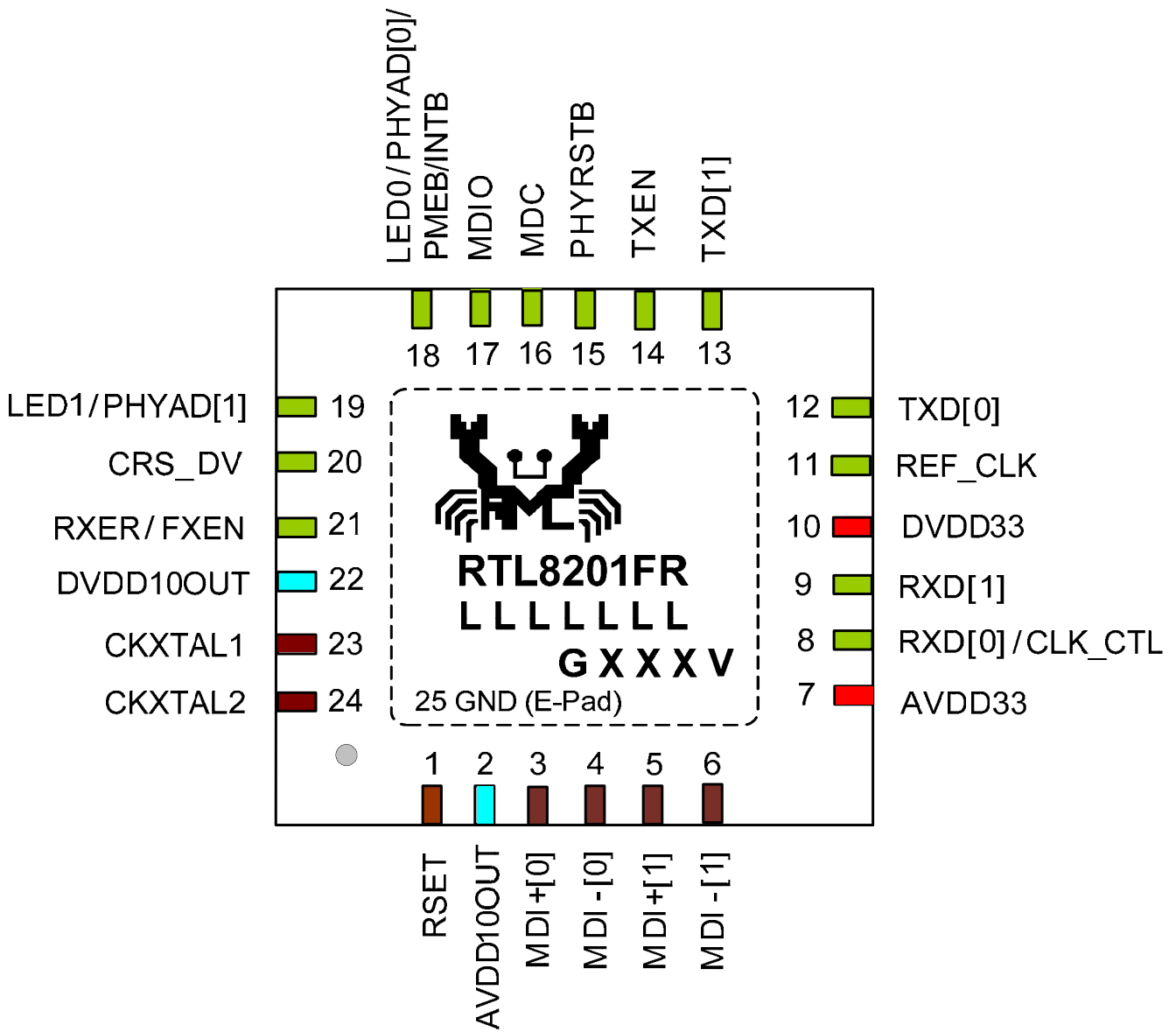

Figure 4. RTL8201FR QFN-24 Pin Assignments

3. Wake-On-LAN (WOL) Flow Chart

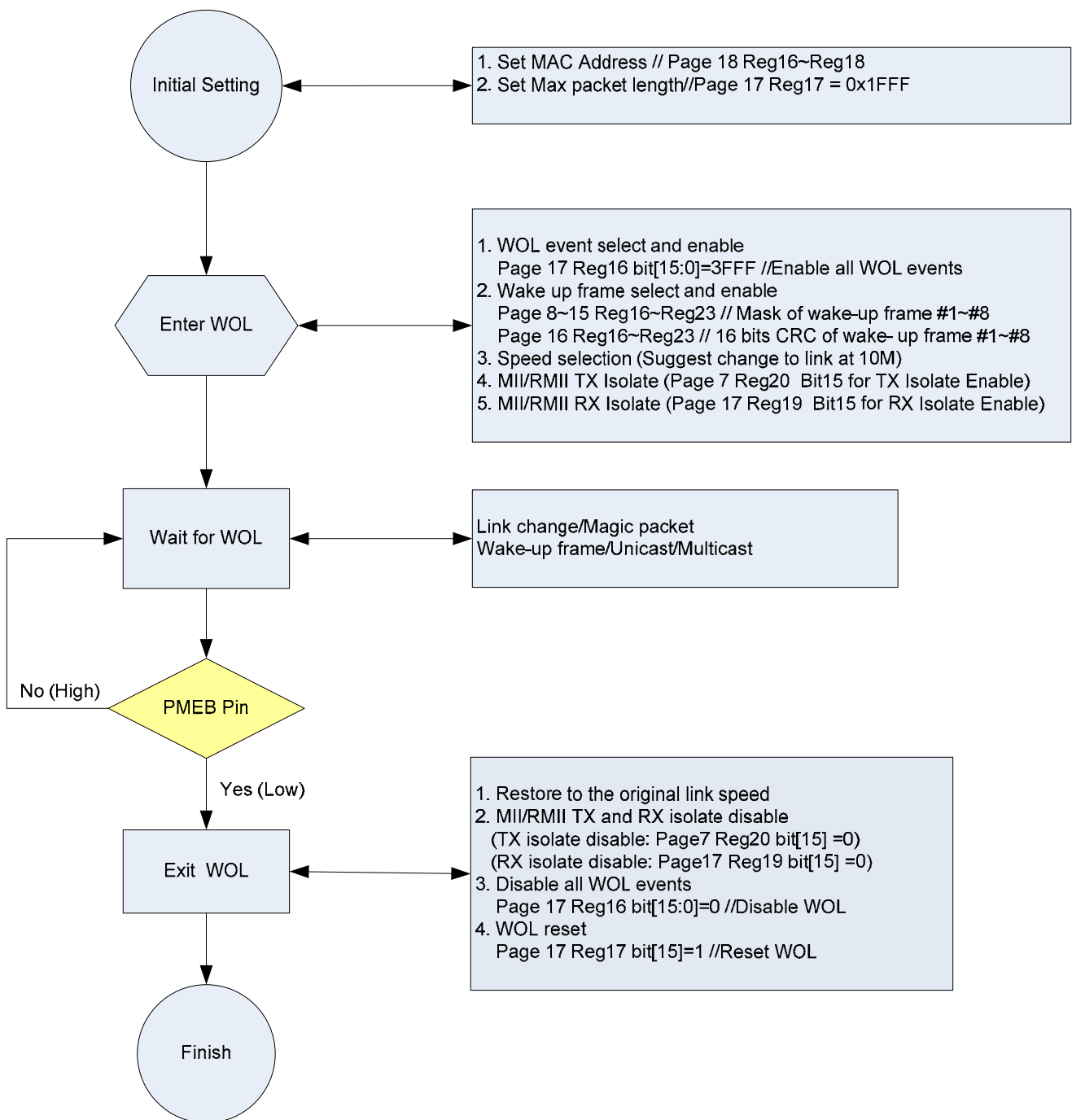

Figure 5. Wake-On-LAN (WOL) Flow Chart

4. Wake-On-LAN (WOL) Register Settings (Page 17)

Enable WOL Link Change Event

Write Register31, Data=0x0011 //Select page 17

Write Register16, Data=0x2000 //Enable Link Change Event

Enable WOL Magic Packet Event (Default)

Write Register31, Data=0x0011 //Select page 17

Write Register16, Data=0x1000 //Enable Magic Packet Event

Enable WOL Unicast Event

Write Register31, Data=0x0011 //Select page 17

Write Register16, Data=0x0400 //Enable Unicast Event

Enable WOL Multicast Event

Write Register31, Data=0x0011 //Select page 17

Write Register16, Data=0x0200 //Enable Multicast Event

Enable WOL Broadcast Event

Write Register31, Data=0x0011 //Select page 17

Write Register16, Data=0x0100 //Enable Broadcast

Enable WOL Wake-Up Frame Event

Write Register31, Data=0x0011 //Select page 17

Write Register16, Data=0x0001 //Enable Wake-Up Frame 0 Event

Write Register16, Data=0x0002 //Enable Wake-Up Frame 1 Event

Write Register16, Data=0x0004 //Enable Wake-Up Frame 2 Event

Write Register16, Data=0x0008 //Enable Wake-Up Frame 3 Event

Write Register16, Data=0x0010 //Enable Wake-Up Frame 4 Event

Write Register16, Data=0x0020 //Enable Wake-Up Frame 5 Event

Write Register16, Data=0x0040 //Enable Wake-Up Frame 6 Event

Write Register16, Data=0x0080 //Enable Wake-Up Frame 7 Event

Enable All WOL Events

Write Register31, Data=0x0011 //Select page 17

Write Register16, Data=0xffff //Enable all Wake-On-LAN Events

Return to Page 0

Write Register31, Data=0x0000 //Return to page 0

Table 1. Page 17, Register 16

Bit	Name	Type	Description	Default Value
15:14	-	RW	Reserved	0
13	linkchg_wol_en	RW	PMEB Asserted due to Detection of a Change in the Network Link State	0
12	magic_en	RW	PMEB Asserted due to Receipt of a Magic Packet	1
11	awf_en	RW	PMEB Asserted due to Receipt of a Network Packet	0
10	uwf_en	RW	PMEB Asserted due to Receipt of a Network Unicast Packet that was Sent to a Local Device	0
9	mwf_en	RW	PMEB Asserted due to Receipt of a Network Multicast Packet that was Sent to a Local Device	0
8	bwf_en	RW	PMEB Asserted due to Receipt of a Network Broadcast Packet	0
7	enwakeup7	RW	PMEB Asserted due to Receipt of Network Wake-Up Frame #7	0
6	enwakeup6	RW	PMEB Asserted due to Receipt of Network Wake-Up Frame #6	0
5	enwakeup5	RW	PMEB Asserted due to Receipt of Network Wake-Up Frame #5	0
4	enwakeup4	RW	PMEB Asserted due to Receipt of Network Wake-Up Frame #4	0
3	enwakeup3	RW	PMEB Asserted due to Receipt of Network Wake-Up Frame #3	0
2	enwakeup2	RW	PMEB Asserted due to Receipt of Network Wake-Up Frame #2	0
1	enwakeup1	RW	PMEB Asserted due to Receipt of Network Wake-Up Frame #1	0
0	enwakeup0	RW	PMEB asserted due to Receipt of Network Wake-Up Frame #0	0

Reset and Maximum Packet Bytes Register

Write Page17 Register17, Data=0x9fff //reset Wake-On-LAN Event (The PMEB pin goes low when a WOL event occurs; write Page17 Register17, Data=0x9fff to reset the PMEB pin back to default status).

Note: The registers remain constant when a WOL reset is enabled. A power on reset or hardware reset can reset all registers back to original values.

Table 2. Page 17, Register 17

Bit	Name	Type	Description	Default Value
15	rg_rst	W	Reset Wake-On-LAN via Register	0
14:0	Rmsq	RW	Defines the Maximum Received Packet Bytes	0

5. Unique Physical Address & Multicast Register (Registers 16~22)

The RTL8201FN/FL/F/FR-VB supports unicast and multicast events. For unicast application it needs to write the MAC address to PHY register 16~18 (page 18).

Refer to Figure 7, page 11 and Table 3, page 12 for multicast application.

//Unicast Example: Set MAC address=00:12:34:56:78:9A

Write Register31, Data=0x0012 //Select page 18

Write Register16, Data=0x1200 (bit [15:8]: MAC address byte2; bit [7:0]: MAC address byte1)

Write Register17, Data=0x5634 (bit [15:8]: MAC address byte4; bit [7:0]: MAC address byte3)

Write Register18, Data=0x9a78 (bit [15:8]: MAC address byte6; bit [7:0]: MAC address byte5)

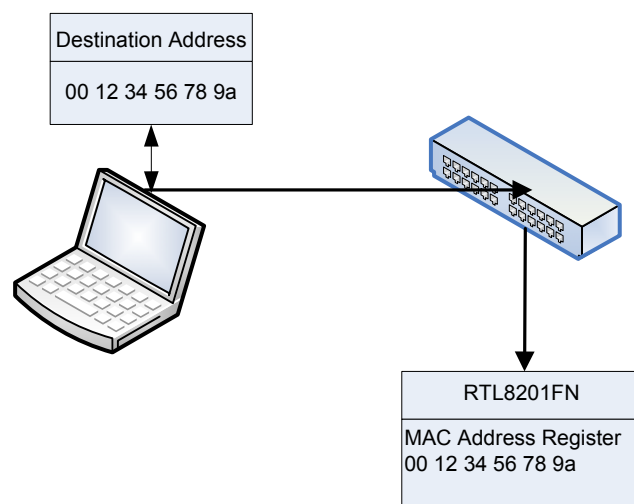

Figure 6. Unicast Application

//Multicast Example: Set Multicast register=01:00:00:00:00:00:00:00

(Destination address is 01, 02, 3C, 00, 00, 00)

Write Register31, Data=0x0012 //Select page 18

Write Register19, Data=0x0000

Write Register20, Data=0x0000

Write Register21, Data=0x0000

Write Register22, Data=0x0100

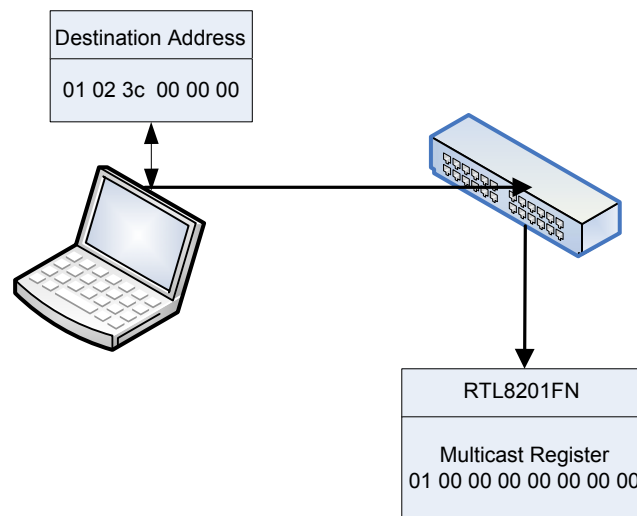

Figure 7. Multicast Application

Table 3. Multicast Pattern and Register

No.	Multicast Pattern	Multicast Register
0	01, 02, 3C, 00, 00, 00	01, 00, 00, 00, 00, 00, 00, 00
1	01, 02, 07, 00, 00, 00	02, 00, 00, 00, 00, 00, 00, 00
2	01, 02, 1F, 00, 00, 00	04, 00, 00, 00, 00, 00, 00, 00
3	01, 02, 24, 00, 00, 00	08, 00, 00, 00, 00, 00, 00, 00
4	01, 02, 28, 00, 00, 00	10, 00, 00, 00, 00, 00, 00, 00
5	01, 02, 13, 00, 00, 00	20, 00, 00, 00, 00, 00, 00, 00
6	01, 02, 0B, 00, 00, 00	40, 00, 00, 00, 00, 00, 00, 00
7	01, 02, 30, 00, 00, 00	80, 00, 00, 00, 00, 00, 00, 00
8	01, 02, 0D, 00, 00, 00	00, 01, 00, 00, 00, 00, 00, 00
9	01, 02, 36, 00, 00, 00	00, 02, 00, 00, 00, 00, 00, 00
10	01, 02, 2E, 00, 00, 00	00, 04, 00, 00, 00, 00, 00, 00
11	01, 02, 15, 00, 00, 00	00, 08, 00, 00, 00, 00, 00, 00
12	01, 02, 19, 00, 00, 00	00, 10, 00, 00, 00, 00, 00, 00
13	01, 02, 22, 00, 00, 00	00, 20, 00, 00, 00, 00, 00, 00
14	01, 02, 3A, 00, 00, 00	00, 40, 00, 00, 00, 00, 00, 00
15	01, 02, 01, 00, 00, 00	00, 80, 00, 00, 00, 00, 00, 00
16	01, 02, 21, 00, 00, 00	00, 00, 01, 00, 00, 00, 00, 00
17	01, 02, 1A, 00, 00, 00	00, 00, 02, 00, 00, 00, 00, 00
18	01, 02, 02, 00, 00, 00	00, 00, 04, 00, 00, 00, 00, 00
19	01, 02, 39, 00, 00, 00	00, 00, 08, 00, 00, 00, 00, 00
20	01, 02, 35, 00, 00, 00	00, 00, 10, 00, 00, 00, 00, 00
21	01, 02, 0E, 00, 00, 00	00, 00, 20, 00, 00, 00, 00, 00
22	01, 02, 16, 00, 00, 00	00, 00, 40, 00, 00, 00, 00, 00
23	01, 02, 2D, 00, 00, 00	00, 00, 80, 00, 00, 00, 00, 00
24	01, 02, 10, 00, 00, 00	00, 00, 00, 01, 00, 00, 00, 00
25	01, 02, 2B, 00, 00, 00	00, 00, 00, 02, 00, 00, 00, 00
26	01, 02, 33, 00, 00, 00	00, 00, 00, 04, 00, 00, 00, 00
27	01, 02, 08, 00, 00, 00	00, 00, 00, 08, 00, 00, 00, 00

No.	Multicast Pattern	Multicast Register
28	01, 02, 04, 00, 00, 00	00, 00, 00, 10, 00, 00, 00, 00
29	01, 02, 3F, 00, 00, 00	00, 00, 00, 20, 00, 00, 00, 00
30	01, 02, 27, 00, 00, 00	00, 00, 00, 40, 00, 00, 00, 00
31	01, 02, 1C, 00, 00, 00	00, 00, 00, 80, 00, 00, 00, 00
32	01, 02, 37, 00, 00, 00	00, 00, 00, 00, 01, 00, 00, 00
33	01, 02, 0C, 00, 00, 00	00, 00, 00, 00, 02, 00, 00, 00
34	01, 02, 14, 00, 00, 00	00, 00, 00, 00, 04, 00, 00, 00
35	01, 02, 2F, 00, 00, 00	00, 00, 00, 00, 08, 00, 00, 00
36	01, 02, 23, 00, 00, 00	00, 00, 00, 00, 10, 00, 00, 00
37	01, 02, 18, 00, 00, 00	00, 00, 00, 00, 20, 00, 00, 00
38	01, 02, 00, 00, 00, 00	00, 00, 00, 00, 40, 00, 00, 00
39	01, 02, 3B, 00, 00, 00	00, 00, 00, 00, 80, 00, 00, 00
40	01, 02, 06, 00, 00, 00	00, 00, 00, 00, 00, 01, 00, 00
41	01, 02, 3D, 00, 00, 00	00, 00, 00, 00, 00, 02, 00, 00
42	01, 02, 25, 00, 00, 00	00, 00, 00, 00, 00, 04, 00, 00
43	01, 02, 1E, 00, 00, 00	00, 00, 00, 00, 00, 08, 00, 00
44	01, 02, 12, 00, 00, 00	00, 00, 00, 00, 00, 10, 00, 00
45	01, 02, 29, 00, 00, 00	00, 00, 00, 00, 00, 20, 00, 00
46	01, 02, 31, 00, 00, 00	00, 00, 00, 00, 00, 40, 00, 00
47	01, 02, 0A, 00, 00, 00	00, 00, 00, 00, 00, 80, 00, 00
48	01, 02, 2A, 00, 00, 00	00, 00, 00, 00, 00, 00, 01, 00
49	01, 02, 11, 00, 00, 00	00, 00, 00, 00, 00, 00, 02, 00
50	01, 02, 09, 00, 00, 00	00, 00, 00, 00, 00, 00, 04, 00
51	01, 02, 32, 00, 00, 00	00, 00, 00, 00, 00, 00, 08, 00
52	01, 02, 3E, 00, 00, 00	00, 00, 00, 00, 00, 00, 10, 00
53	01, 02, 05, 00, 00, 00	00, 00, 00, 00, 00, 00, 20, 00
54	01, 02, 1D, 00, 00, 00	00, 00, 00, 00, 00, 00, 40, 00
55	01, 02, 26, 00, 00, 00	00, 00, 00, 00, 00, 00, 80, 00
56	01, 02, 1B, 00, 00, 00	00, 00, 00, 00, 00, 00, 00, 01

No.	Multicast Pattern	Multicast Register
57	01, 02, 20, 00, 00, 00	00, 00, 00, 00, 00, 00, 00, 02
58	01, 02, 38, 00, 00, 00	00, 00, 00, 00, 00, 00, 00, 04
59	01, 02, 03, 00, 00, 00	00, 00, 00, 00, 00, 00, 00, 08
60	01, 02, 0F, 00, 00, 00	00, 00, 00, 00, 00, 00, 00, 10
61	01, 02, 34, 00, 00, 00	00, 00, 00, 00, 00, 00, 00, 20
62	01, 02, 2C, 00, 00, 00	00, 00, 00, 00, 00, 00, 00, 40
63	01, 02, 17, 00, 00, 00	00, 00, 00, 00, 00, 00, 00, 80

Table 4. Page 18

Reg	Bit	Name	Type	Description	Default Value
16	15:0	uni_phy_addr[15:0]	RW/EFUS	Unique Physical Address (MAC Address)	0
17	15:0	uni_phy_addr[31:16]	RW/EFUS	Unique Physical Address (MAC Address)	0
18	15:0	uni_phy_addr[47:32]	RW/EFUS	Unique Physical Address (MAC Address)	0
19	15:0	multicast_register[15:0]	RW	Multicast Register	0
20	15:0	multicast_register[31:16]	RW	Multicast Register	0
21	15:0	multicast_register[47:32]	RW	Multicast Register	0
22	15:0	multicast_register[63:48]	RW	Multicast Register	0

6. Wake-Up Frame Mask & CRC Setting (Page 8~16, Register 16~23)

Pages 8 to 15 are Wake-Up Frame mask registers that support Wake-Up Frame 0 to 7.

Page 16 is the Wake-Up Frame CRC register.

6.1. Set Wake-Up Frame Mask

Example: Set Wake-Up Frame Mask=0x00 03 C0 00 20 30 00

Packet data: (Red color is the MASK)

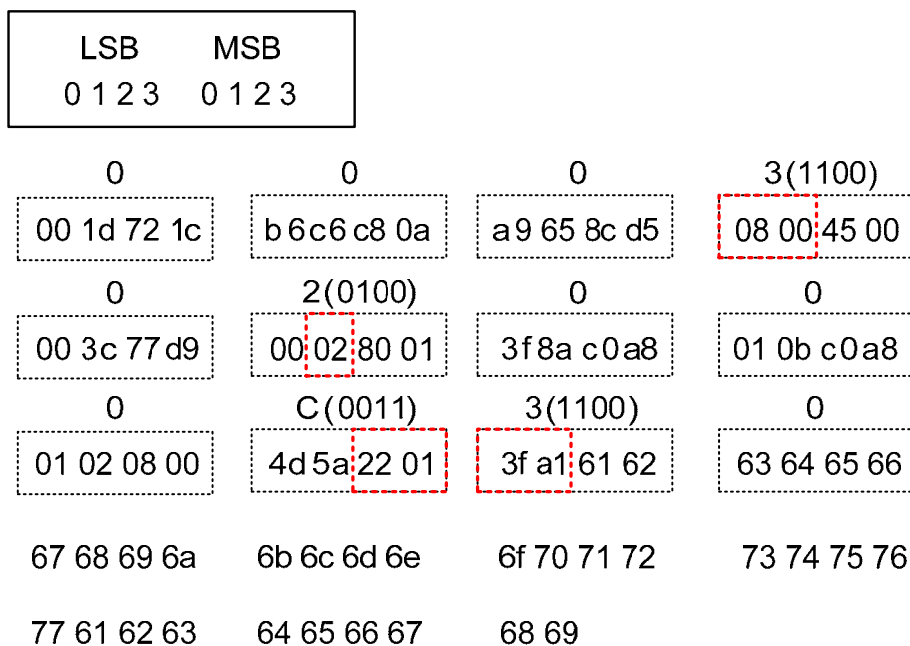

Figure 8. Set Wake-Up Frame Mask

Masked Bytes are used to calculate the CRC: 0x08, 0x00, 0x02, 0x22, 0x01, 0x3f, 0xa1

//Example: Write page8 for Wake-Up Frame 0 mask:

Write Register31, Data=0x0008 //Select page 8 (Wake-Up Frame 0)

Write Register16, Data=0x3000

Write Register17, Data=0x0020

Write Register18, Data=0x03c0

Write Register19, Data=0x0000

Write Register20, Data=0x0000

Write Register21, Data=0x0000

Write Register22, Data=0x0000

Write Register23, Data=0x0000

Table 5. Page 8 (Wake-Up Frame 0)

Reg	Bit	Name	Type	Description	Default Value
16	15:0	byte_msk_wf0[15:0]	RW	Byte Masks of Wake-Up Frame #0 for Power Management	0
17	15:0	byte_msk_wf0[31:16]	RW	Byte Masks of Wake-Up Frame #0 for Power Management	0
18	15:0	byte_msk_wf0[47:32]	RW	Byte Masks of Wake-Up Frame #0 for Power Management	0
19	15:0	byte_msk_wf0[63:48]	RW	Byte Masks of Wake-Up Frame #0 for Power Management	0
20	15:0	byte_msk_wf0[79:64]	RW	Byte Masks of Wake-Up Frame #0 for Power Management	0
21	15:0	byte_msk_wf0[95:80]	RW	Byte Masks of Wake-Up Frame #0 for Power Management	0
22	15:0	byte_msk_wf0[111:96]	RW	Byte Masks of Wake-Up Frame #0 for Power Management	0
23	15:0	byte_msk_wf0[127:112]	RW	Byte Masks of Wake-Up Frame #0 for Power Management	0

Table 6. Page 9 (Wake-Up Frame 1)

Reg	Bit	Name	Type	Description	Default Value
16	15:0	byte_msk_wf1[15:0]	RW	Byte Masks of Wake-Up Frame #1 for Power Management	0
17	15:0	byte_msk_wf1[31:16]	RW	Byte Masks of Wake-Up Frame #1 for Power Management	0
18	15:0	byte_msk_wf1[47:32]	RW	Byte Masks of Wake-Up Frame #1 for Power Management	0
19	15:0	byte_msk_wf1[63:48]	RW	Byte Masks of Wake-Up Frame #1 for Power Management	0
20	15:0	byte_msk_wf1[79:64]	RW	Byte Masks of Wake-Up Frame #1 for Power Management	0
21	15:0	byte_msk_wf1[95:80]	RW	Byte Masks of Wake-Up Frame #1 for Power Management	0
22	15:0	byte_msk_wf1[111:96]	RW	Byte Masks of Wake-Up Frame #1 for Power Management	0
23	15:0	byte_msk_wf1[127:112]	RW	Byte Masks of Wake-Up Frame #1 for Power Management	0

Table 7. Page 10 (Wake-Up Frame 2)

Reg	Bit	Name	Type	Description	Default Value
16	15:0	byte_msk_wf2[15:0]	RW	Byte Masks of Wake-Up Frame #2 for Power Management	0
17	15:0	byte_msk_wf2[31:16]	RW	Byte Masks of Wake-Up Frame #2 for Power Management	0
18	15:0	byte_msk_wf2[47:32]	RW	Byte Masks of Wake-Up Frame #2 for Power Management	0
19	15:0	byte_msk_wf2[63:48]	RW	Byte Masks of Wake-Up Frame #2 for Power Management	0
20	15:0	byte_msk_wf2[79:64]	RW	Byte Masks of Wake-Up Frame #2 for Power Management	0
21	15:0	byte_msk_wf2[95:80]	RW	Byte Masks of Wake-Up Frame #2 for Power Management	0
22	15:0	byte_msk_wf2[111:96]	RW	Byte Masks of Wake-Up Frame #2 for Power Management	0
23	15:0	byte_msk_wf2[127:112]	RW	Byte Masks of Wake-Up Frame #2 for Power Management	0

Table 8. Page 11 (Wake-Up Frame 3)

Reg	Bit	Name	Type	Description	Default Value
16	15:0	byte_msk_wf3[15:0]	RW	Byte Masks of Wake-Up Frame #3 for Power Management	0
17	15:0	byte_msk_wf3[31:16]	RW	Byte Masks of Wake-Up Frame #3 for Power Management	0
18	15:0	byte_msk_wf3[47:32]	RW	Byte Masks of Wake-Up Frame #3 for Power Management	0
19	15:0	byte_msk_wf3[63:48]	RW	Byte Masks of Wake-Up Frame #3 for Power Management	0

Reg	Bit	Name	Type	Description	Default Value
20	15:0	byte_msk_wf3[79:64]	RW	Byte Masks of Wake-Up Frame #3 for Power Management	0
21	15:0	byte_msk_wf3[95:80]	RW	Byte Masks of Wake-Up Frame #3 for Power Management	0
22	15:0	byte_msk_wf3[111:96]	RW	Byte Masks of Wake-Up Frame #3 for Power Management	0
23	15:0	byte_msk_wf3[127:112]	RW	Byte Masks of Wake-Up Frame #3 for Power Management	0

Table 9. Page 12 (Wake-Up Frame 4)

Reg	Bit	Name	Type	Description	Default Value
16	15:0	byte_msk_wf4[15:0]	RW	Byte Masks of Wake-Up Frame #4 for Power Management	0
17	15:0	byte_msk_wf4[31:16]	RW	Byte Masks of Wake-Up Frame #4 for Power Management	0
18	15:0	byte_msk_wf4[47:32]	RW	Byte Masks of Wake-Up Frame #4 for Power Management	0
19	15:0	byte_msk_wf4[63:48]	RW	Byte Masks of Wake-Up Frame #4 for Power Management	0
20	15:0	byte_msk_wf4[79:64]	RW	Byte Masks of Wake-Up Frame #4 for Power Management	0
21	15:0	byte_msk_wf4[95:80]	RW	Byte Masks of Wake-Up Frame #4 for Power Management	0
22	15:0	byte_msk_wf4[111:96]	RW	Byte Masks of Wake-Up Frame #4 for Power Management	0
23	15:0	byte_msk_wf4[127:112]	RW	Byte Masks of Wake-Up Frame #4 for Power Management	0

Table 10. Page 13 (Wake-Up Frame 5)

Reg	Bit	Name	Type	Description	Default Value
16	15:0	byte_msk_wf5[15:0]	RW	Byte Masks of Wake-Up Frame #5 for Power Management	0
17	15:0	byte_msk_wf5[31:16]	RW	Byte Masks of Wake-Up Frame #5 for Power Management	0
18	15:0	byte_msk_wf5[47:32]	RW	Byte Masks of Wake-Up Frame #5 for Power Management	0
19	15:0	byte_msk_wf5[63:48]	RW	Byte Masks of Wake-Up Frame #5 for Power Management	0
20	15:0	byte_msk_wf5[79:64]	RW	Byte Masks of Wake-Up Frame #5 for Power Management	0
21	15:0	byte_msk_wf5[95:80]	RW	Byte Masks of Wake-Up Frame #5 for Power Management	0
22	15:0	byte_msk_wf5[111:96]	RW	Byte Masks of Wake-Up Frame #5 for Power Management	0
23	15:0	byte_msk_wf5[127:112]	RW	Byte Masks of Wake-Up Frame #5 for Power Management	0

Table 11. Page 14 (Wake-Up Frame 6)

Reg	Bit	Name	Type	Description	Default Value
16	15:0	byte_msk_wf6[15:0]	RW	Byte Masks of Wake-Up Frame #6 for Power Management	0
17	15:0	byte_msk_wf6[31:16]	RW	Byte Masks of Wake-Up Frame #6 for Power Management	0
18	15:0	byte_msk_wf6[47:32]	RW	Byte Masks of Wake-Up Frame #6 for Power Management	0
19	15:0	byte_msk_wf6[63:48]	RW	Byte Masks of Wake-Up Frame #6 for Power Management	0
20	15:0	byte_msk_wf6[79:64]	RW	Byte Masks of Wake-Up Frame #6 for Power Management	0
21	15:0	byte_msk_wf6[95:80]	RW	Byte Masks of Wake-Up Frame #6 for Power Management	0
22	15:0	byte_msk_wf6[111:96]	RW	Byte Masks of Wake-Up Frame #6 for Power Management	0
23	15:0	byte_msk_wf6[127:112]	RW	Byte Masks of Wake-Up Frame #6 for Power Management	0

Table 12. Page 15 (Wake-Up Frame 7)

Reg	Bit	Name	Type	Description	Default Value
16	15:0	byte_msk_wf7[15:0]	RW	Byte Masks of Wake-Up Frame #7 for Power Management	0
17	15:0	byte_msk_wf7[31:16]	RW	Byte Masks of Wake-Up Frame #7 for Power Management	0
18	15:0	byte_msk_wf7[47:32]	RW	Byte Masks of Wake-Up Frame #7 for Power Management	0
19	15:0	byte_msk_wf7[63:48]	RW	Byte Masks of Wake-Up Frame #7 for Power Management	0
20	15:0	byte_msk_wf7[79:64]	RW	Byte Masks of Wake-Up Frame #7 for Power Management	0
21	15:0	byte_msk_wf7[95:80]	RW	Byte Masks of Wake-Up Frame #7 for Power Management	0
22	15:0	byte_msk_wf7[111:96]	RW	Byte Masks of Wake-Up Frame #7 for Power Management	0
23	15:0	byte_msk_wf7[127:112]	RW	Byte Masks of Wake-Up Frame #7 for Power Management	0

6.2. Set Wake-Up Frame CRC

//Example: Set Wake-Up Frame CRC=0xdf6b

Write Register31, Data=0x0010 //Select page 16

Write Register16, Data=0xdf6b //Set Wake-Up Frame #0 CRC=0xdf6b

Table 13. Page 16 (WOL_Wake_CRC)

Reg	Bit	Name	Type	Description	Default Value
16	15:0	wfcrc0	RW	16-Bit CRC of Wake-Up Frame #0	0
17	15:0	wfcrc1	RW	16-Bit CRC of Wake-Up Frame #1	0
18	15:0	wfcrc2	RW	16-Bit CRC of Wake-Up Frame #2	0
19	15:0	wfcrc3	RW	16-Bit CRC of Wake-Up Frame #3	0
20	15:0	wfcrc4	RW	16-Bit CRC of Wake-Up Frame #4	0
21	15:0	wfcrc5	RW	16-Bit CRC of Wake-Up Frame #5	0
22	15:0	wfcrc6	RW	16-Bit CRC of Wake-Up Frame #6	0
23	15:0	wfcrc7	RW	16-Bit CRC of Wake-Up Frame #7	0

Set Wake-Up Frame for WOL example as follows:

1. Set maximum packet and WOL event

Write Register31, Data = 0x0011 //Select Page 17

Write Register17, Data=0x9FFF //Maximum packet length

Write Register16, Data =0x0001 //Enable WOL Wake-Up Frame 0 event

2. Set MAC address = 00:12:34:56:78:9A

Write Register31, Data =0x0012 //Select page 18

Write Register16, Data =0x1200

Write Register17, Data =0x5634

Write Register18, Data =0x9a78

3. Set Wake-Up Frame mask; Wake-Up Frame mask = 0x0000_03C0_0020_3000

Write Register31, Data=0x0008 //Select page 8

Write Register16, Data =0x3000

Write Register17, Data =0x0020

Write Register18, Data =0x03C0

Write Register19, Data =0x0000

Write Register20, Data =0x0000

Write Register21, Data =0x0000

Write Register22, Data =0x0000

Write Register23, Data =0x0000

4. Set Wake-Up Frame CRC

Write Register31, Data =0x0010 //Select page 16

Write Register16, Data =0xdf6b //Set Wake-Up Frame #0 CRC = 0xdf6b

5. Enable MII/RMII TX isolation for power saving

Write Register31, Data =0x0007 //Select page 7

Write Register20, Data =0x90d3 //Enable TX isolation

6. Enable MII/RMII RX isolation for power saving

Write Register31, Data =0x0011 //Select page 17

Write Register19, Data =0x8002 //Enable RX isolation

7. Wake-On-LAN (WOL) Pin Types

The signal type codes below are used in the following tables:

I: Input	LI: Latched Input during Power Up or Reset
O: Output	L: Low
IO: Bi-Directional Input and Output	PD: Internal Pull Down during Power On Reset
PU: Internal Pull Up during Power On Reset	

7.1. MII Interface

Table 14. MII Interface

Name	Type	Normal			WOL Enable
		100M	10M	Idle	
TXC	O/PD	25M CLK Output	2.5M CLK Output	2.5M CLK Output	O (2.5M/25M)/L/PD (Note 1)
TXEN	I/PD	I	I	I	I/PD
TXD[0:3]	I/PD	I	I	I	I/PD
RXC	O/PD	25M CLK Output	2.5M CLK Output	2.5M CLK Output	O (2.5M/25M)/L (Note 2)
COL	LI/O/PD	O	O	O	O or L (Note 2)
CRS	O/PD	O	O	O	O or L (Note 2)
RXDV	LI/O/PD	O	O	O	O or L (Note 2)
RXD[0:3]	O/PD	O	O	O	O or L (Note 2)
RXER	LI/O/PD	O	O	O	O or L (Note 2)
MDC	I/PU	I	I	I	I/PU
MDIO	IO/PU	IO	IO	IO	IO/PU

Note 1: If TX Isolate=1, then TXC is halted and the TXC pin type is 'L'.

To set the TXC pin type to 'PD', set page0, register0, bit10=0.

Note 2: If RX Isolate=1, Rx_CLK isolate=1, all MII RX interfaces are stopped and the MII RX pin type is Low.

If RX Isolate=1, Rx_CLK isolate=0, the RXC signal is toggled. The other MII RX interfaces are stopped and the MII RX pin type is Low.

If RX Isolate=0, Rx_CLK isolate=0, all MII RX signals are toggled.

7.2. RMI Interface

Table 15. RMI Interface

Name	Type	Normal			WOL Enable
		100M	10M	Idle	
TXC (REF_CLK) (Note 1)	IO/PD	50M CLK Input/Output	50M CLK Input/Output	50M CLK Input/Output	I/O (50M) (Note 2)
TXEN	I/PD	I	I	I	I/PD
TXD[0:1]	I/PD	I	I	I	I/PD
CRS_DV	O/PD	O	O	O	O or L (Note 3)
RXD[0:1]	O/PD	O	O	O	O or L (Note 3)
RXER	LI/O/PD	O	O	O	O or L (Note 3)
MDC	I/PU	I	I	I	I/PU
MDIO	IO/PU	IO	IO	IO	IO/PU

Note 1: If TXC (REF_CLK) is in input mode (MAC to PHY), the REF_CLK does not stop when WOL is enabled.

Note 2: When REF_CLK is in output mode (PHY to MAC), the REF_CLK never stops (always toggling; 50MHz output).

To set the TXC pin type to 'PD', set page0, register0, bit10=1.

Note 3: If RX Isolate=1, all RMI RX interfaces are stopped and the RMI RX pin type is Low.

8. Magic Packet/Wake-Up Frame Wakeup

Magic Packet Format

6 * FFh + MISC (can be none) + 16 * DID (Destination ID)

Wake-Up Frame Format

16-bit CRC of the received Wake-Up Frame matches the 16-bit CRC of the sample Wake-Up Frame pattern by the local machine's OS.

Other Wake-Up Frame Types are:

- Broadcast: Wakes on Ethernet Broadcast of FF FF FF FF FF FF
- Unicast: Wakes if the header of the packet includes the Device Under Test (DUT) MAC Address (i.e., 11:82:07:BC:13:70)
- Multicast: Wakes if the header of the packet includes the DUT MAC Address (i.e., 11:82:07:BC:13:70)

8.1. Wake-On-LAN (WOL) Circuit

The RTL8201F/FL/FN/FR-VB can monitor the network for a Wake-Up Frame or a Magic Packet, and notify the system via the PME_B (Power Management Event; ‘B’ means low active) pin when such a packet or event occurs. The system can then be restored to a normal state to process incoming jobs. The PME_B pin must be connected with a 4.7k-ohm resistor and pulled up to 3.3V.

See the following sections for PME_B pin function selection in the RTL8201F-VB and RTL8201FR-VB. No PME_B pin function selection is required in the RTL8201FL-VB and RTL8201FN-VB models.

8.1.1. RTL8201F PME_B Pin Function Selection

Method 1: RXD [1] PIN external weakly pulled high

Method 2: Write page7, register19, bit10=1

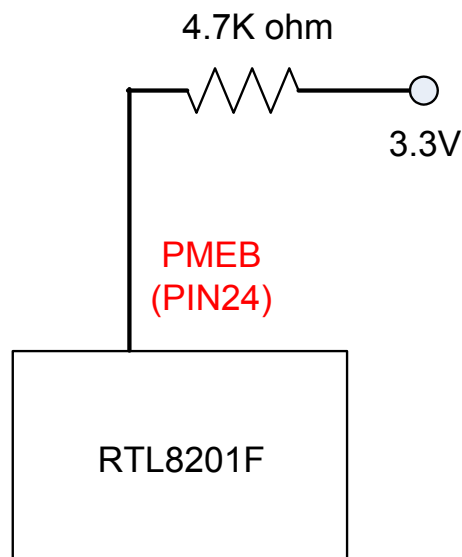

Figure 9. RTL8201F Wake-On-LAN (WOL) Circuit

8.1.2. RTL8201FR PME B Pin Function Selection

Method 1: RXD [1] PIN external weakly pulled high

Method 2: Write page7, register19, bit10=1

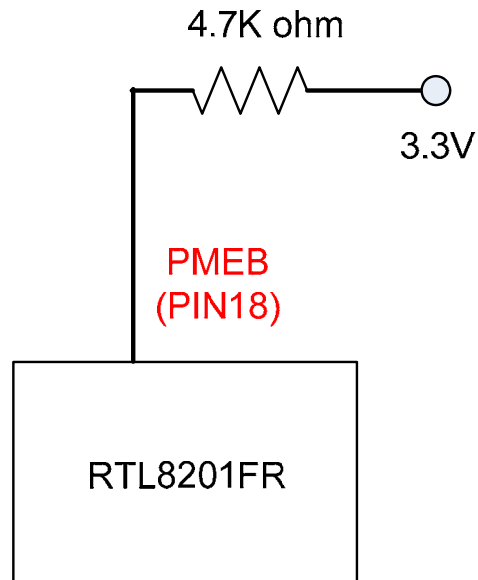

Figure 10. RTL8201FR Wake-On-LAN (WOL) Circuit

8.2. Active Low Wakeup

For enhanced PHY power saving, the RTL8201FN/FL/F/FR-VB supports the MII/RMII Interface RX isolation feature for isolation between PHY and MAC in WOL mode. The MII/RMII pins will be output low when RX isolation is enabled (via register; see Table 16).

Table 16. Page 17, Reg19, Bit15 (RX Isolate Enable) (Active Low)

Reg	Bit	Name	Type	Description	Default Value
19	15	Rg_wol_rx_iso_en	RW	0: Disable MII/RMII RX Isolate in WOL 1: Enable MII/RMII RX Isolate in WOL	0

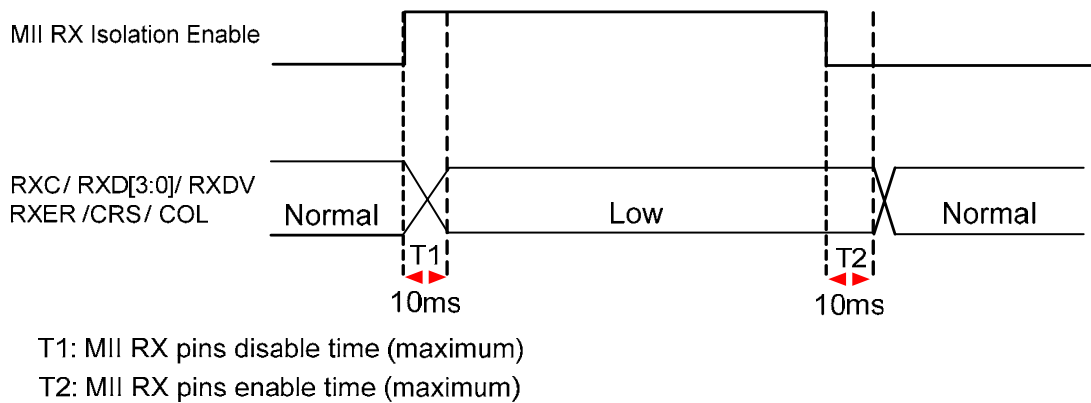

Figure 11. MII RX Isolation Timing

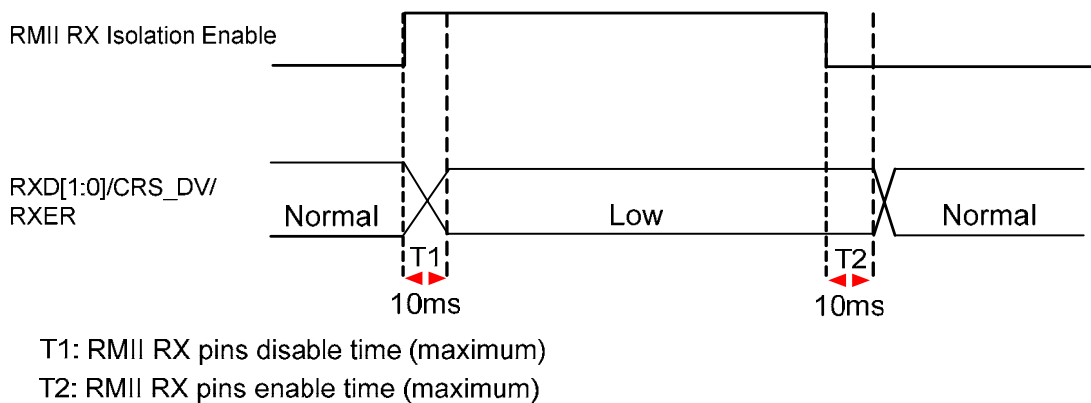

Figure 12. RMII RX Isolation Timing

Table 17. Page 17, Reg19, Bit14 (RXC Halt/Toggle Selection) (Active Low)

Reg	Bit	Name	Type	Description	Default Value
19	14	Rg_wol_rxc_on	RW	Force MII Mode RXC ON when MII RX Isolate is Enabled 1: RXC toggle 0: RXC Halt	0

Table 18. Page 7, Reg20, Bit15 (TX Isolate Enable) (Active Low)

Reg	Bit	Name	Type	Description	Default Value
20	15	Rg_tx_iso_en	RW	Isolate MII/RMII TX when TX Idle <i>Note: TX isolate can be used when the TX path is idle (not only for WOL).</i>	0

8.2.1. RX Isolate=1 (TX may or may not be set to isolated)

MII Mode -- PME B Active Low After Receiving Magic Packet or Wake-Up Frame

(Not Available for the RTL8201FR-VB)

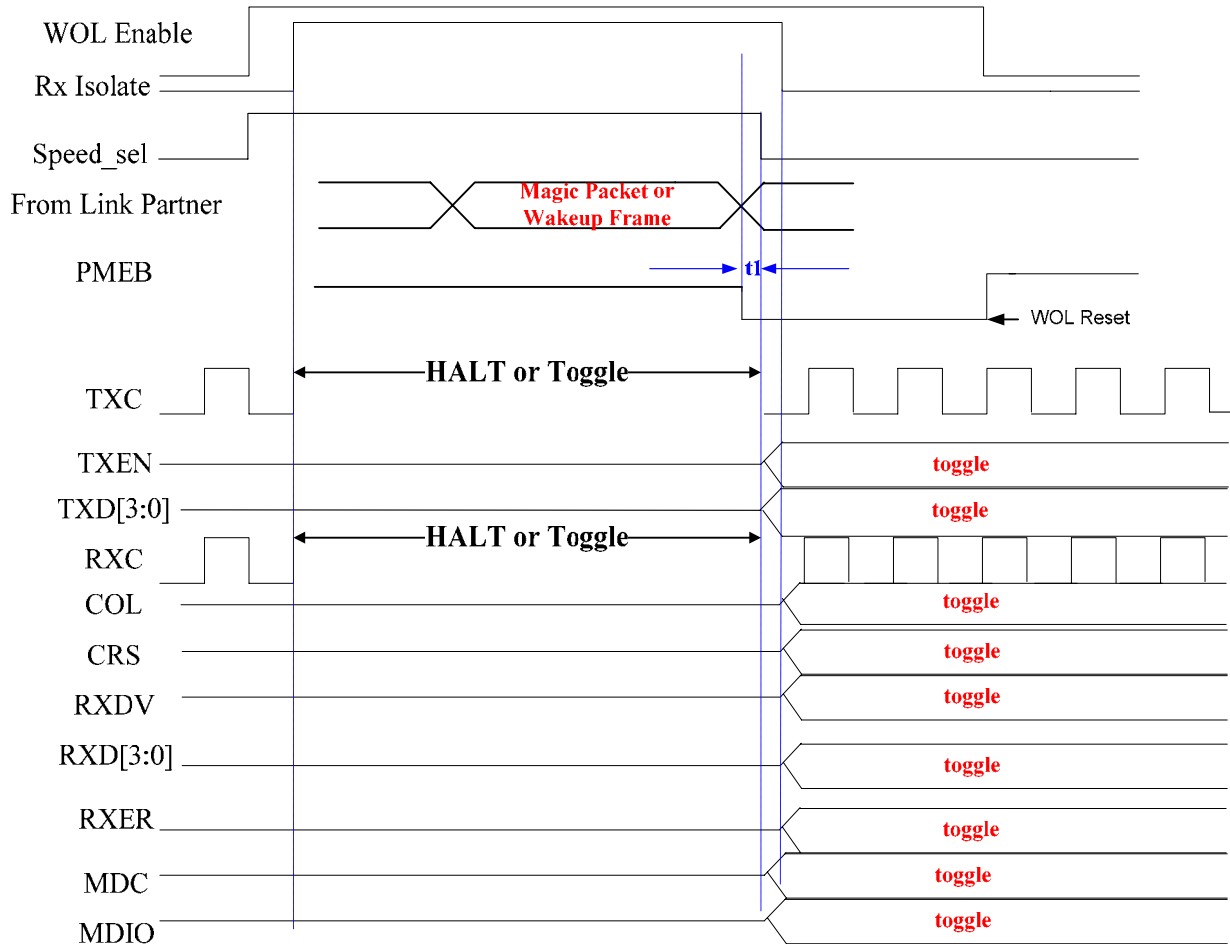

Figure 13. WOL Waveform with RX Isolate=1 in MII Mode (Active Low)

Note 1: Assumes that MAC TXEN, TXD [3:0], MDC and MDIO are set to not toggle during MAC sleep.

Note 2: t1 is the MAC Wakeup time.

Note 3: TXC and RXC can be halted or kept toggling in MII mode via register settings.

Note 4: Speed_sel=0 → MAC sets PHY speed=100M; Speed_sel=1 → MAC sets PHY speed=10M.

Note 5: PME B Pin should be reset at WOL disable.

Note 6: PHYRSTB will be pulled high during WOL operation.

RMII Mode -- PMEB Active Low After Receiving Magic Packet or Wake-Up Frame

Figure 14. WOL Waveform with RX Isolate=1 in RMII Mode (Active Low)

Note 1: Assumes that MAC TXEN, TXD [1:0], MDC and MDIO are set to not toggle during MAC sleep.

Note 2: $t1$ is the MAC Wakeup time.

Note 3: TXC cannot be halted in TXC input mode. TXC can be halted or kept toggling when TXC is in output mode.

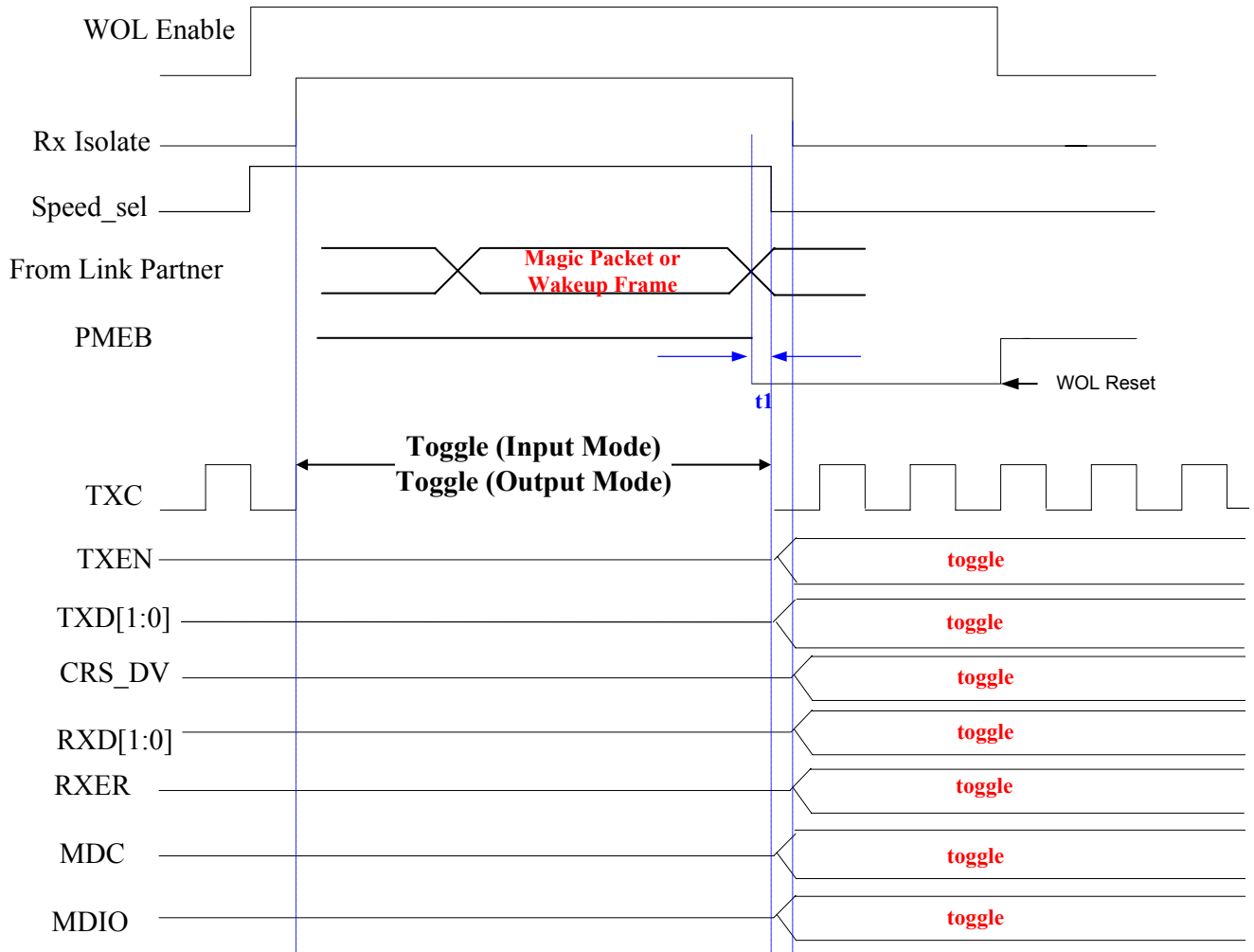
Note 4: Speed_sel=0 → MAC sets PHY speed=100M; Speed_sel=1 → MAC sets PHY speed=10M.

Note 5: PMEB Pin should be reset at WOL disable.

Note 6: PHYRSTB will be pulled high during WOL operation.

8.2.2. RX Isolate=0 (TX Isolate=0)

MII Mode -- PME B Active Low After Receiving Magic Packet or Wake-Up Frame

(Not Available for the RTL8201FR-VB)

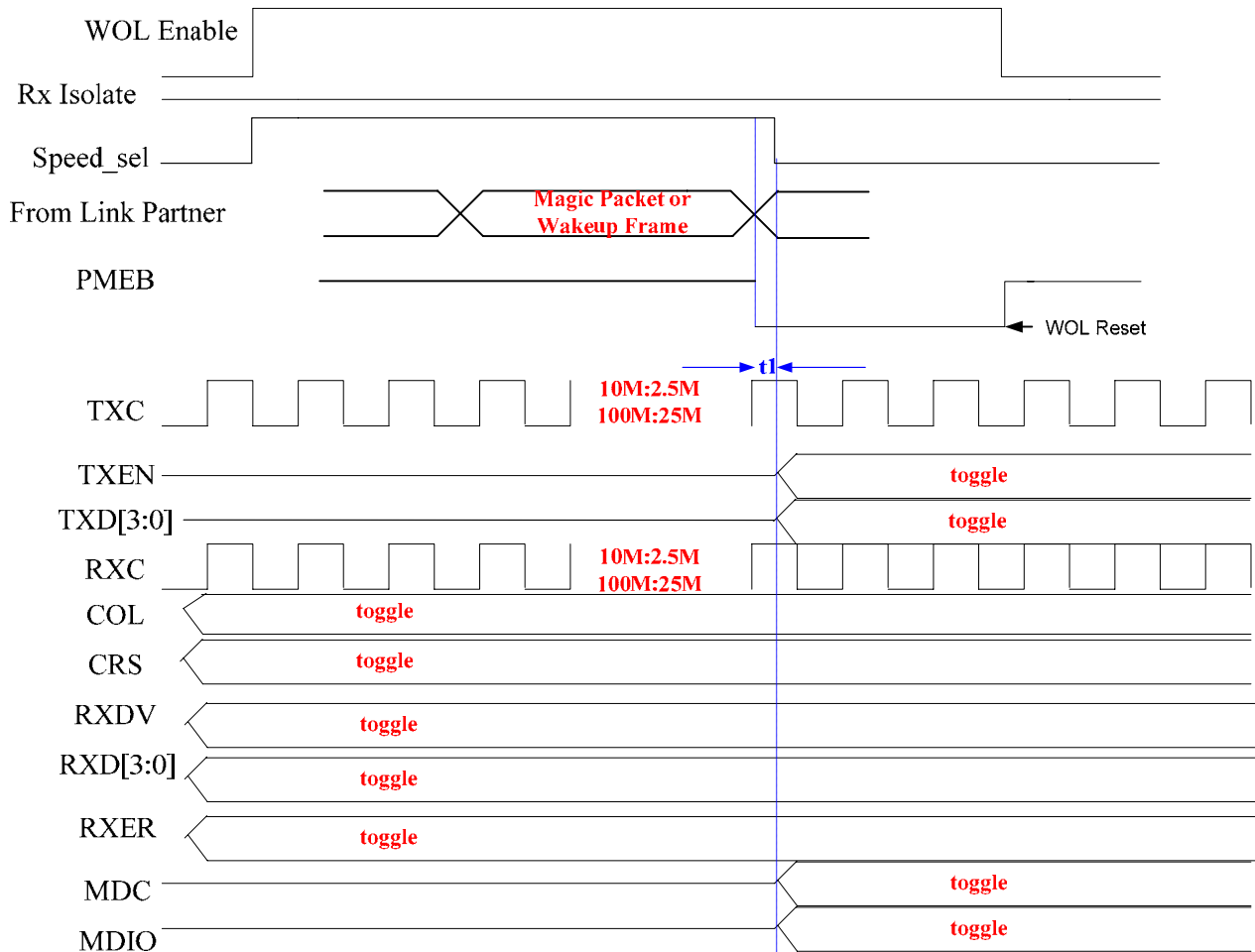

Figure 15. WOL Waveform with RX Isolate=0 and TX Isolate=0 in MII Mode (Active Low)

Note 1: Assumes that MAC TXEN, TXD [3:0], MDC and MDIO are set to not toggle during MAC sleep.

Note 2: t1 is the MAC Wakeup time.

Note 3: In MII mode we recommend setting TXC to toggle.

Note 4: Speed_sel=0 → MAC sets PHY speed=100M; Speed_sel=1 → MAC sets PHY speed=10M.

Note 5: PME B Pin should be reset at WOL disable.

Note 6: PHYRSTB will be pulled high during WOL operation.

RMII Mode -- PMEB Active Low After Receiving Magic Packet or Wake-Up Frame

Figure 16. WOL Waveform with RX Isolate=0 and TX Isolate=0 in MII Mode (Active Low)

- Note 1: Assumes that MAC TXEN, TXD [1:0], MDC and MDIO are set to not toggle during MAC sleep.*
- Note 2: t_1 is the MAC Wakeup time.*
- Note 3: TXC cannot be halted in TXC input mode. TXC can be halted or kept toggling when TXC is in output mode.*
- Note 4: Speed_sel=0 → MAC sets PHY speed=100M; Speed_sel=1 → MAC sets PHY speed=10M.*
- Note 5: PMEB Pin should be reset at WOL disable.*
- Note 6: PHYRSTB will be pulled high during WOL operation.*

8.3. Pulse Low Wakeup

Table 19. Page 17, Reg19, Bit15 (RX Isolate Enable) (Pulse Low)

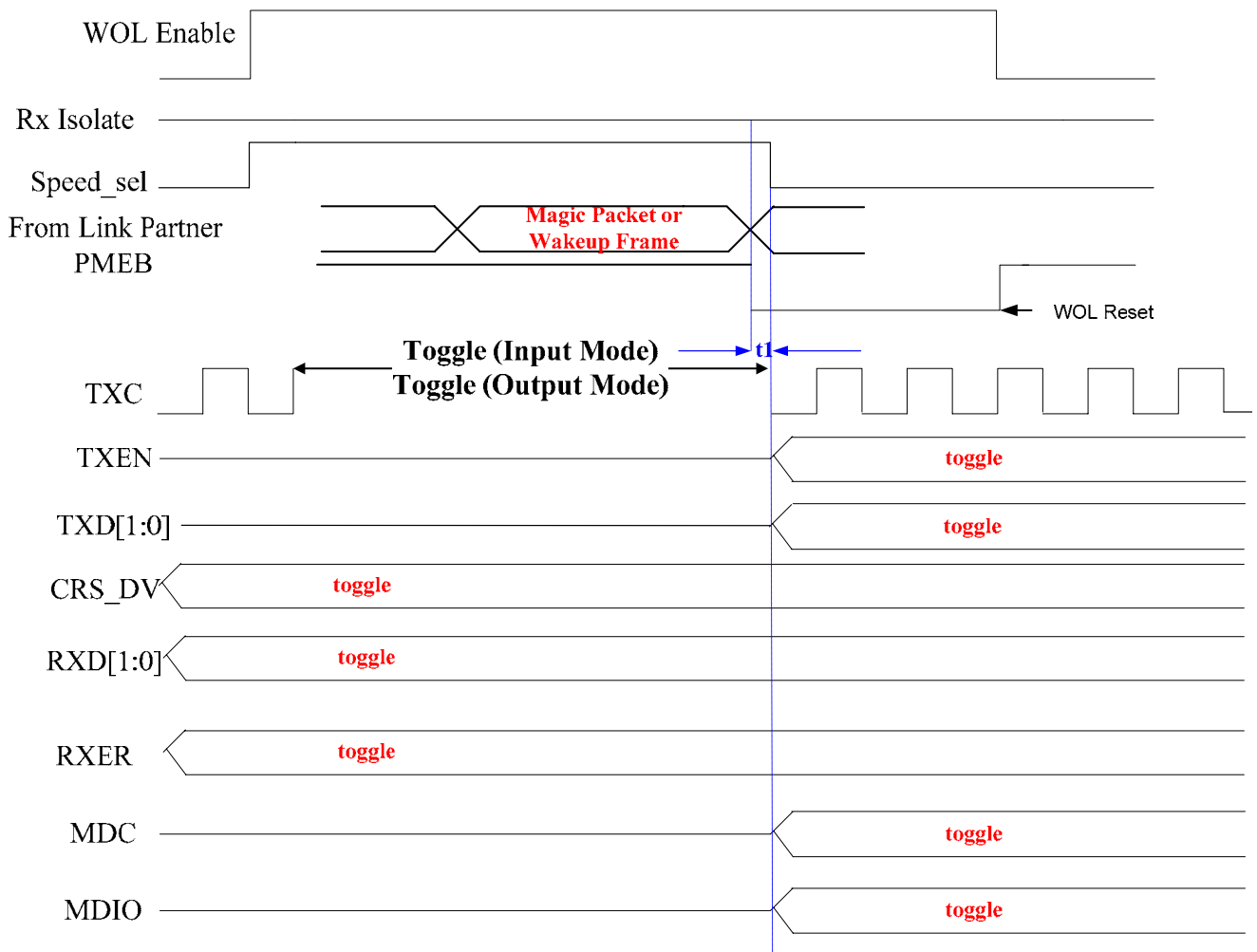
Reg	Bit	Name	Type	Description	Default Value
19	15	Rg_wol_rx_iso_en	RW	0: Disable MII/RMII RX Isolate in WOL 1: Enable MII/RMII RX Isolate in WOL	0

Table 20. Page 17, Reg19, Bit14 (RXC Halt/Toggle Selection) (Pulse Low)

Reg	Bit	Name	Type	Description	Default Value
19	14	Rg_wol_rxc_on	RW	Force MII Mode RXC ON when Enable MII RX Isolate 1: RXC toggle 0: RXC halt	0

Table 21. Page 7, Reg20, Bit15 (TX Isolate Enable) (Pulse Low)

Reg	Bit	Name	Type	Description	Default Value
20	15	Rg_tx_iso_en	RW	Isolate MII/RMII TX when TX Idle <i>Note: TX isolate can be used when the TX path is idle (not only for WOL).</i>	0

Table 22. Page 17, Reg19, Bit [2:0] (PMEB Pulse Width & Active Low/Pulse Low Settings)

Reg	Bit	Name	Type	Description	Default Value
19	2:1	Rg_pmeb_pulse_width	RW	Pulse Width of PMEB Pin 00: 84ms 01: 168ms (Default) 10: 336ms 11: 772ms	01
19	0	Rg_pmeb_pulse_ena	RW	PMEB Active Low/Pulse Low Setting 1: Pulse Low wake-up 0: Active low wake-up	0

8.3.1. RX Isolate=1 (TX may or may not be set to isolated)

MII Mode -- PME_B Pulse Low After Receiving Magic Packet or Wake-Up Frame

(Not Available for the RTL8201FR-VB)

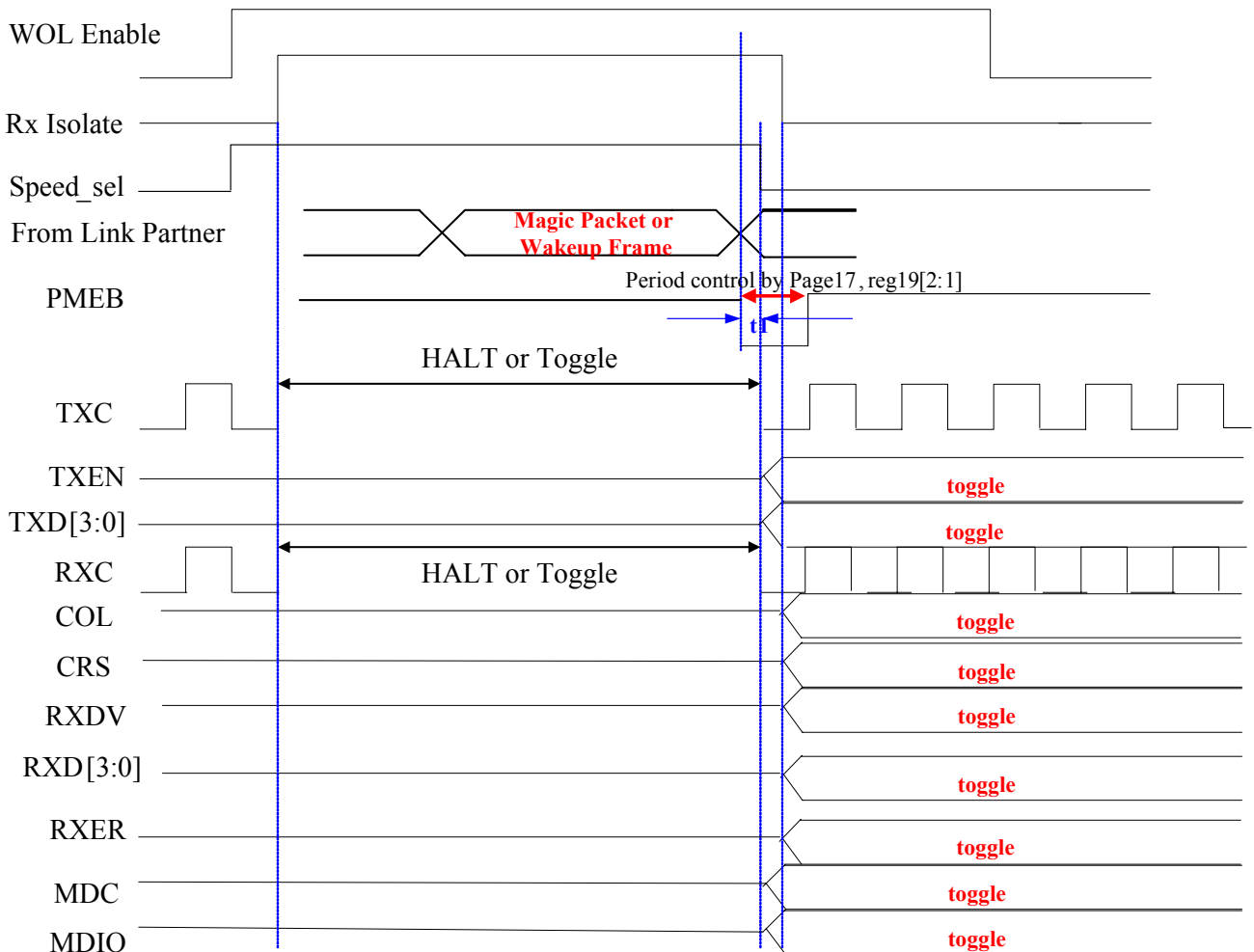

Figure 17. WOL Waveform with RX Isolate=1 in MII Mode (Pulse Low)

Note 1: Assumes that MAC TXEN, TXD [3:0], MDC and MDIO are set to not toggle during MAC sleep.

Note 2: t1 is the MAC Wakeup time.

Note 3: TXC and RXC can be halted or kept toggling in MII mode via register settings.

Note 4: Speed_sel=0 → MAC sets PHY speed=100M; Speed_sel=1 → MAC sets PHY speed=10M.

Note 5: PHYRSTB will be pulled high during WOL operation.

RMII Mode -- PMEB Pulse Low After Receiving Magic Packet or Wake-Up Frame

Figure 18. WOL Waveform with RX Isolate=1 in RMII Mode (Pulse Low)

- Note 1: Assumes that MAC TXEN, TXD [1:0], MDC and MDIO are set to not toggle during MAC sleep.*
- Note 2: t1 is the MAC Wakeup time.*
- Note 3: TXC cannot be halted in TXC input mode. TXC can be halted or kept toggling when TXC is in output mode.*
- Note 4: Speed_sel=0 → MAC sets PHY speed=100M; Speed_sel=1 → MAC sets PHY speed=10M.*
- Note 5: PHYRSTB will be pulled high during WOL operation.*

8.3.2. RX Isolate=0 (TX Isolate=0)

MII Mode -- PME_B Pulse Low After Receiving Magic Packet or Wake-Up Frame

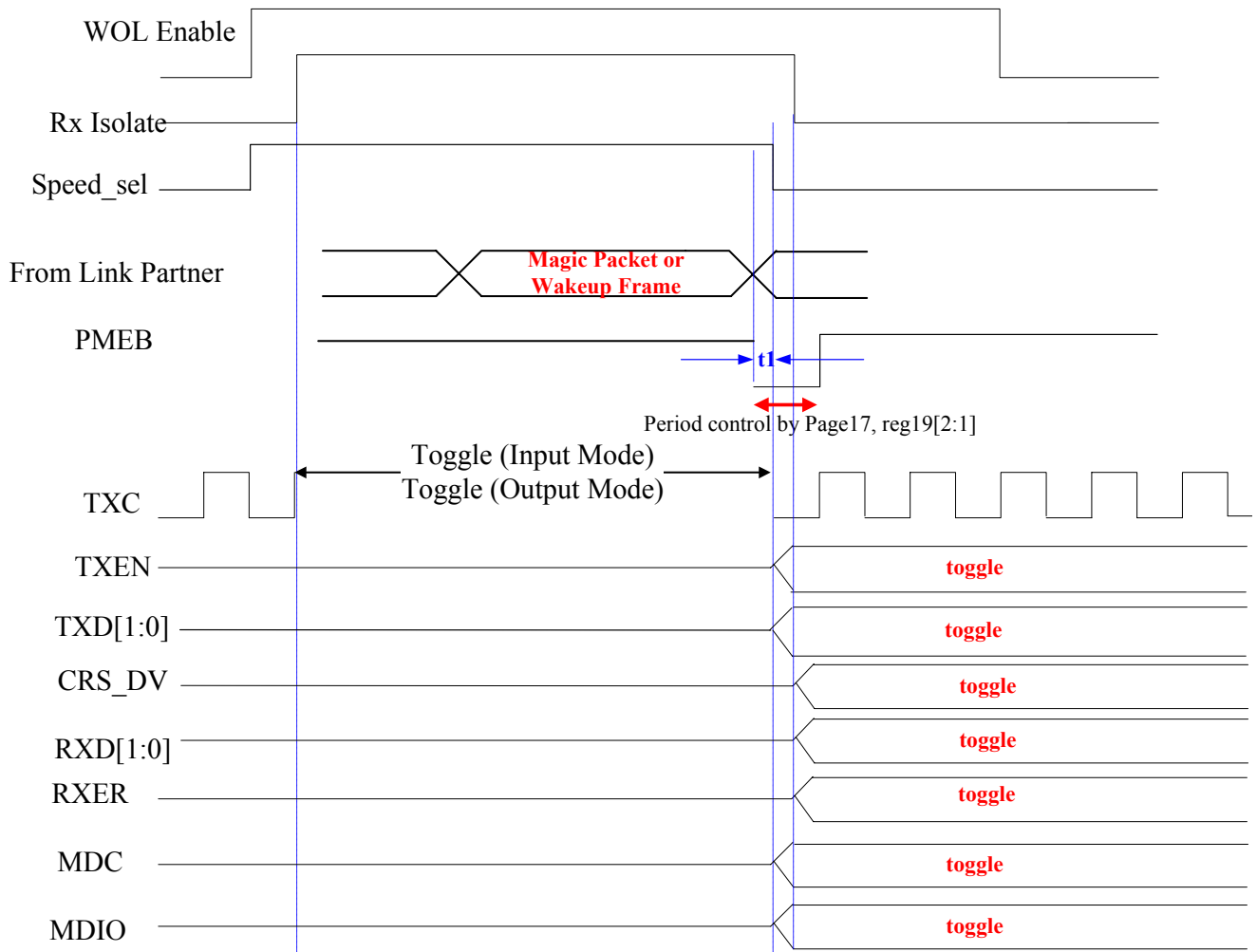
(Not Available for the RTL8201FR-VB)

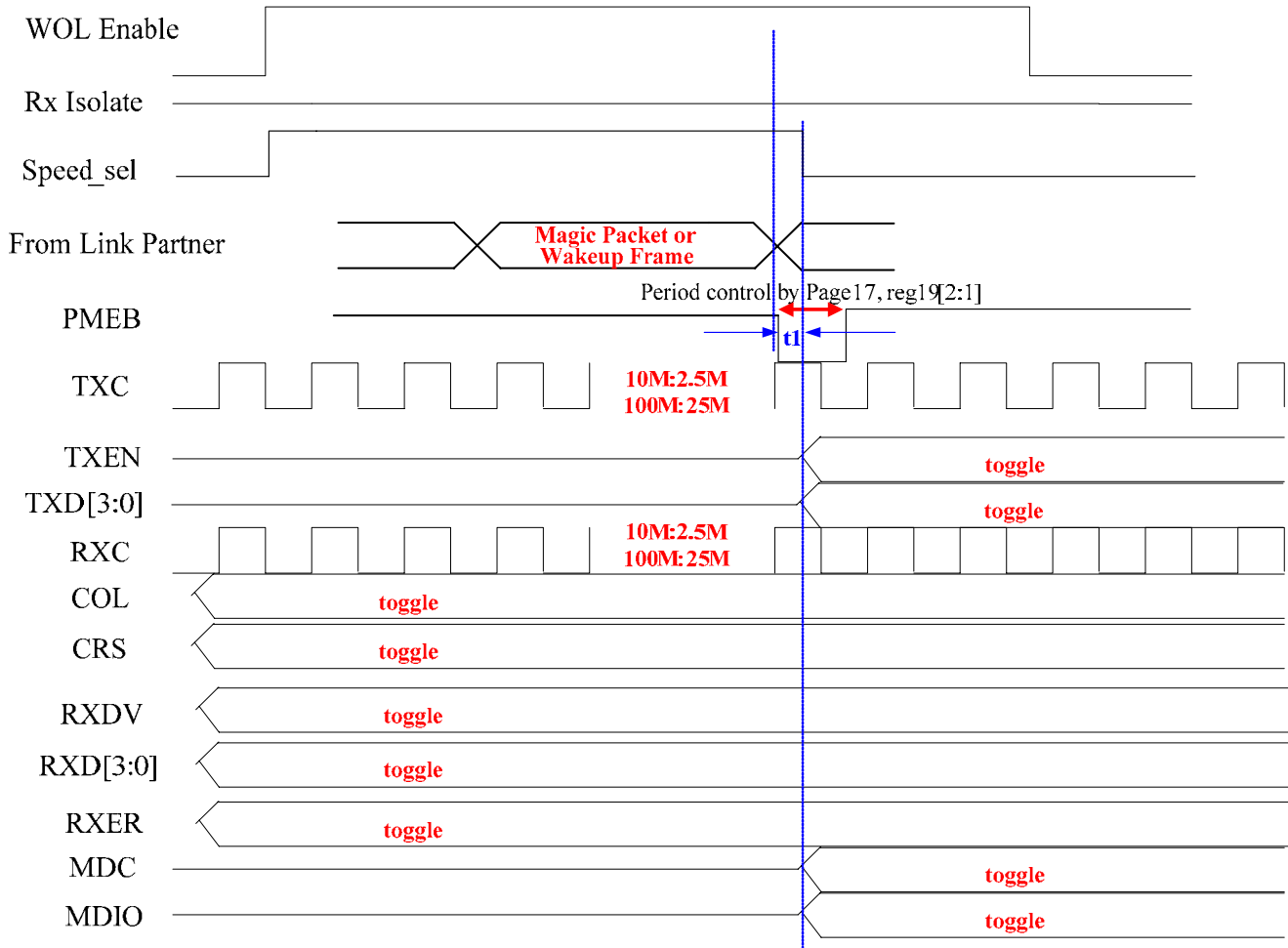

Figure 19. WOL Waveform with RX Isolate=0 and TX Isolate=0 in MII Mode (Pulse Low)

Note 1: Assumes that MAC TXEN, TXD [3:0], MDC and MDIO are set to not toggle during MAC sleep.

Note 2: t_1 is the MAC Wakeup time.

Note 3: In MII mode we recommend setting TXC to toggle.

Note 4: Speed_sel=0 → MAC sets PHY speed=100M; Speed_sel=1 → MAC sets PHY speed=10M.

Note 5: PHYRSTB will be pulled high during WOL operation.

RMII Mode -- PME_B Pulse Low After Receiving Magic Packet or Wake-Up Frame

Figure 20. WOL Waveform with RX Isolate=0 and TX Isolate=0 in RMII Mode (Pulse Low)

Note 1: Assumes that MAC TXEN, TXD [1:0], MDC and MDIO are set to not toggle during MAC sleep.

Note 2: t_1 is the MAC Wakeup time.

Note 3: TXC cannot be halted in TXC input mode. TXC can be halted or kept toggling when TXC is in output mode.

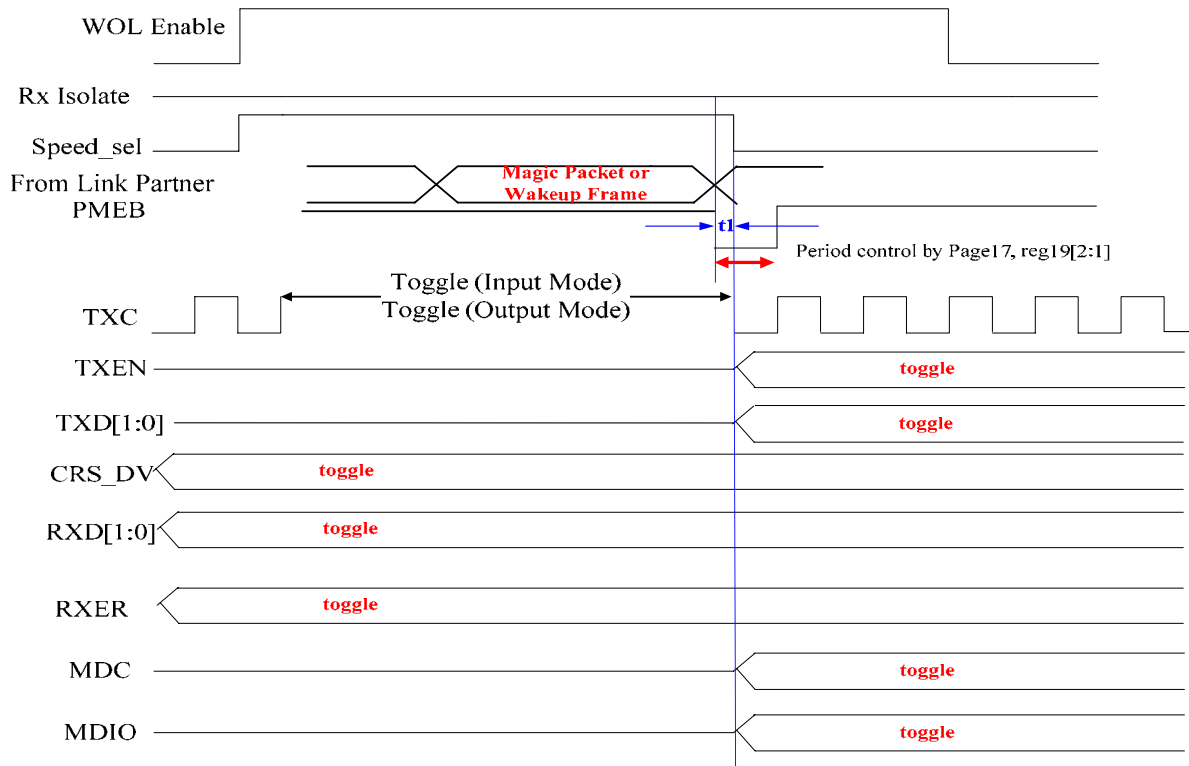
Note 4: Speed_sel=0 → MAC sets PHY speed=100M; Speed_sel=1 → MAC sets PHY speed=10M.

Note 5: PHYRSTB will be pulled high during WOL operation.

Realtek Semiconductor Corp.
Headquarters

No. 2, Industry East Road IX, Science-based
Industrial Park, Hsinchu, 300, Taiwan, R.O.C.

Tel: 886-3-5780211 Fax: 886-3-5776047

www.realtek.com